

## Nails in New Zealand 1770 to 1910

---

Nigel Isaacs

### Introduction

The British colony of New Zealand developed under the glow of the industrial revolution. The wealth, resources and technology of the British Empire spread a red swath across the globe, initially exporting manufactured product but later the production plant and skills. For example, barbed wire was being made in New Zealand in 1882, albeit from the imported “best Staffordshire hoop iron”<sup>1</sup> while corrugated iron roofing was being made by 1886<sup>2</sup> from English black iron.<sup>3</sup> It could reasonably be expected that local nail manufacture would have developed to support the extensive use of timber construction. However, although different authors have postulated the existence of an indigenous nail manufacturing industry in the mid- to late-1800s there has been no systematic effort to identify the possible location, size or production of such an industry.<sup>4,5,6</sup>

This paper reviews the earliest records of metal nails in New Zealand, and then provides a comprehensive New Zealand review from the 1840s to 1910s of nail imports; published newspapers; trade catalogues; and patents. It concludes that while there may have been a small scale hand-made nail industry, it was not until the late 1880s that the first wire nails were manufactured in New Zealand and not until after 1910 that the industry became established to any extent.

### Earliest European Visitors

Prior to the arrival of European explorers, New Zealand’s indigenous people, the Maori, did not have metal. Their buildings were made of plants or trees, often in combination with earth. Reed or thatching was woven into place by vines or sewn with fibre from flax or other leaves.<sup>7</sup> One view of early Maori housing was that “one is impressed not by their strength, but by their frailty”.<sup>8</sup> Stone was widely used for tools, weapons and ornaments.<sup>9</sup>

When Captain James Cook arrived in New Zealand in 1769, he recorded in his journal that the Maori did not recognise iron nails:

“Wednesday, 15th [November 1769]. ... [Sail from Mercury Bay, Coromandel Peninsula, North Island – 36° 49’ S 175° 44’ E] ... Neither of the Inhabitants of this Place, nor any other where we have been, know the use of Iron or set the least Value upon it, preferring the most Trifling thing we could give them to a Nail, or any sort of Iron Tools.”<sup>10</sup>

Throughout the Pacific, Cook traded iron nails for food and *mana* (status), while once the value of iron nails had been recognised by the native peoples his men found other opportunities, including payment for prostitution.<sup>11</sup> Yet in on 19 June 1770, when his ship Endeavour needed repair at Endeavour River, Queensland, possibly the first nails manufactured in the Pacific were made as in Roman times – by blacksmith forging each one.<sup>12</sup>

### Early European Settlers

New Zealand became a colony of Great Britain with the signing of the “Treaty of Waitangi” in 1840.

Following this, the number of colonists rapidly increased – by 1842 there were 10,932 civil European settlers in the main towns and settlements, with an estimated 100,000 to 150,000 indigenous Maori.<sup>13</sup> Even from the earliest days, there was a strong preference for wooden housing (Table 1).<sup>14</sup> After forty-six years of colonisation, the 1886 Census<sup>15</sup> reported a total of 121,951 houses, of which 106,189 (87%) were made of wood – the remaining 13% were mainly of stone or brick, mud or tent.

Table 1: Count of Houses by Main Materials by Census Year

Census Year	Count by House construction			Total
	Wood	Stone or Brick	Other materials	
1858	10,179	307	2,326	12,812
1861	15,139	477	6,782	22,398
1864	25,463	1,082	11,451	37,996
1867	38,844	1,182	13,989	54,015
1871	45,951	1,540	9,691	57,182
1874	54,523	2,042	9,293	65,858
1878	73,366	3,223	11,792	88,381
1881	87,646	4,062	11,627	103,335
1886	106,189	5,252	10,510	121,951
1891	116,801	5,697	11,336	133,834
1896	134,092	6,490	9,340	149,922
1901	153,945	7,517	9,131	170,593
1906	178,551	8,359	10,093	197,003
1911	209,760	9,650	12,757	232,167

Although prior to 1862 no nail import statistics are available, newspaper advertisements and shipping reports from 1840 provide information. For example, the shipping report of the 7 March 1840 lists the arrival at Wellington from London of the New Zealand Company ship *Glenbervie*, carrying 20 kegs of nails for three different retail and auction businesses (1 keg = 100 lb or 45.4 kg), as well as many ‘packages’ and ‘crates’<sup>16</sup>, which possibly included nails directly ordered from England by settlers.

Imported Nail Supplies

From the first newspapers in 1840, hardware advertisements were differentiating country, manufacture and type of nails – Table 2 provides some examples, although it is not intended as a comprehensive survey.<sup>17</sup>

The 18 April 1840 issue of the *New Zealand Gazette*, the first locally printed issue, included two advertisements for nails. The business of Hunter and Co advertised ‘Iron bar, bolt, nail and sheet’ landed from the ‘*Glenbervie*’, while the ‘*Britannia Hotel and Stores*’ advertised ‘Nails direct from Britannia Works’, which most likely refers to the Britannia Nail Works of Birmingham, England.<sup>18</sup>

A common trade name found in the nail advertisements was the British Ewbank Patent Wrought Nail. Ewbank nails were reportedly first made in 1835 at J. J. Corde & Co.’s *Dos Works* in Monmouthshire<sup>19</sup> and were available in the Australian colonies in by 1844<sup>20</sup> and in New Zealand by at least 1847. Ewbank’s nails were widely available. In Auckland, Connell & Ridings were advertising ‘20 Kegs Ewbank’s Patent Wrought Nails from 1½ to 3 inches’ to be sold at auction on 12 July 1848.<sup>21</sup>

Table 2: Examples of Nail Descriptions in Newspaper Advertisements 1840-1872

Date	Newspaper (Page)	Description
18 April 1840	NZ Gazette (p 1)	‘Nails direct from Britannia Works’ ‘Iron bar, bolt, nail and sheet’
5 November 1840	NZ Advertiser & Bay of Islands Gazette (p 2)	‘Wrought & cut nails’
9 November 1842	NZ Gazette and Wellington Spectator (p 1)	‘Nails of every description’
6 March 1847	New Zealander (p 1)	‘Patent and Cut Nails’
21 August 1847	Daily Southern Cross (p 1)	‘Ewbank’s Nails’
8 July 1848	Daily Southern Cross (p 1)	‘20 Kegs Ewbank’s Patent Wrought Nails from 1½ to 3 inches’
8 January 1863	Daily Southern Cross (p 3)	‘American nails, 2 5/8d. to 2 7/8 d. per lb’
28 July 1863	Daily Southern Cross (p 2)	‘French wire nails, 1½ in’
18 August 1865	Daily Southern Cross (p 1)	‘Ewbank’s’, ‘Light’ & ‘Wire Nails’
15 September 1865	Daily Southern Cross (p 7)	‘Ewbank’s Nails’, ‘American Cut Nails’
5 July 1866	Daily Southern Cross (p 5)	‘Ewbank’s & American Cut, French Wire’
27 November 1872	Daily Southern Cross (p 1)	‘French Wire Nails’ & ‘English Wire Nails’

In Wellington, Bethune and Hunter advertised for sale in August 1849 ‘62 kegs assorted Ewbank’s Patent Nails’ due to arrive on the ship *Jane Catherine* and ‘78 kegs Ewbank’s Patent Nails’ which had arrived on the ship *Ennerdale* on 5 June 1849.<sup>22</sup> Across Cook Strait, on 24 October 1857 in Nelson, D. Moore was advertising ‘50 casks Ewbank’s patent nails, assorted’ on page 1 of the *Nelson Examiner and New Zealand Chronicle* while competitor T. C. Batchelor was advertising ‘60 kegs of Ewbank’s patent wrought nails, from 1 ¼ in to 6 in.’ on page 4.<sup>23</sup> No comparable brand name was promoted for American nails (most likely cut nails, even when not specifically stated), possibly reflecting a wide variety of suppliers.<sup>24</sup>

As the New Zealand nail market developed, different countries provided supply. When S. Hague Smith announced the closing sale for his upper Queen Street, Auckland shop in 1868, it included ‘Ewbank’s, Wire and American Nails’.<sup>25</sup> In 1873, J. & J. Dickey of Auckland were selling ‘Ewbank’s and Cut Nails, French Wire Nails, 1 in. to 3 in., American Finishing Nails, ½ in. to 2½ in.’<sup>26</sup> Although in a country dependent on imports it is not surprising that English, French and American nails were available, it is notable that the merchants considered it worthwhile to differentiate between them. Even as late as 1895, McCallum and Co of Oamaru were advertising the availability of generic as well as branded nails - ‘Wire nails, Floor Brads, Ewbank Nails, Roofing Nails’.<sup>27</sup>

The technology for wire nails originated in France early in the nineteenth century, although there were French patents for wire nails beginning from 1806.<sup>28</sup> Machine-made wire nails (points de Paris) were exhibited at the 1844 and 1855 Paris Exhibitions<sup>29</sup>, and at the 1851 London Great Exhibition at the Crystal Palace.<sup>30</sup> Although wire nails were first made in USA the 1850s, these were smaller sizes and it was not until the 1870s that they were commonly made for construction.<sup>31</sup> By 1888 wire nails were less than a fifth of total production (the rest being cut nails) but grew by 1895 to nearly three quarters. Wire nail production rose from 20,000 kegs in 1880 to 125,000 kegs in 1887, while prices fell from US\$ 20.00 per keg in 1875 to US\$ 10.00 in 1880 to US\$ 4.81 in 1887 – possibly below the cost of production.<sup>32</sup>

One consequence of this array of nail imports is that it is not uncommon to find a variety of nails in old buildings. Figure 1 shows a selection of nails found in 1994 renovations of the house at 5 Poplar Grove, Thorndon, Wellington, originally built about 1880-2. The hand-forged 4 inch nail, cut floor brad, Ewbank nail and the two types of cut nails reflect not only on the original construction but also the work carried out over many years. Unsurprisingly, more recent work used wire nails.

Sample of Nails recovered from 5 Poplar Grove, Wellington during work in 1994

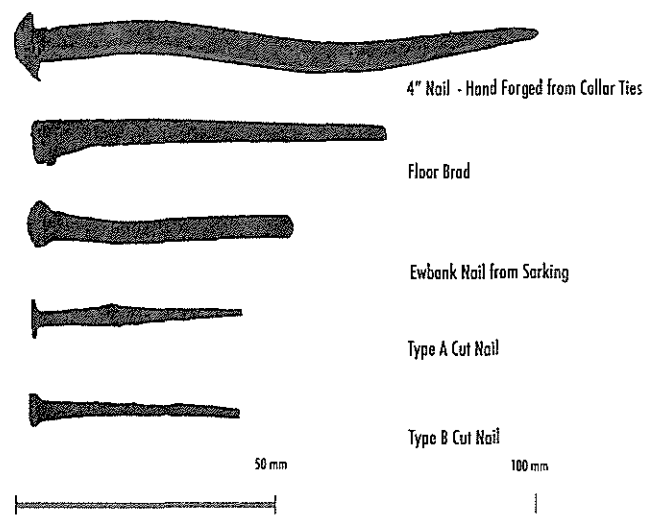

Figure 1. Sample of Nails Recovered in 1994 from 5 Poplar Grove, Thorndon, Wellington (Built circa 1882) (Source: Martin Hill Collection, VUW)

**Import Statistics**

It was not until 1869 that the official New Zealand import statistics were reported by country of origin, although import value and quantity are available from 1862.<sup>33</sup> Figure 2 plots nail imports by weight and main locations from 1869 to 1910, grouping the official statistics by country as follows (main suppliers in *italics*):

- Australia:** *NSW, Victoria, Tasmania and Western Australia*
- U.S.A.:** *Atlantic (East) and Pacific (West) Coasts*
- Europe:** *Germany, Belgium, Holland, Norway, Sweden and Italy*
- Other:** includes China, Tonga, Fiji and South Seas Islands

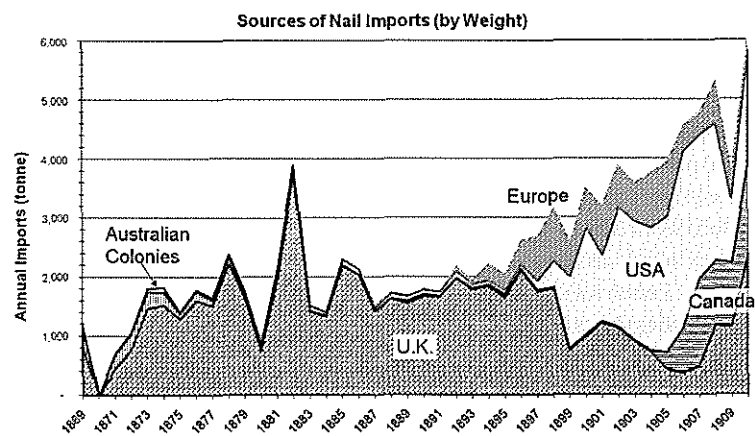

Figure 2. Sources of nail imports 1869-1910 – weight

Very few nails were imported from these “Other” countries – the highest levels of imports was in 1877 when 90 cwt were imported at a cost of £92 (1 cwt = 1 hundredweight = 112 pounds = 50.8 kg).

Although imports were attributed to the country of shipping origin, this is may not have been the country of manufacture. For example, in 1877 when total nail imports totalled 32,634 cwt of value £34,531, only 88 cwt of nails (value £91) were sourced from Fiji. Whether this was an indigenous Fijian industry or re-directed exports from another country cannot be determined.

Although some nail imports were later exported, for the purpose of this paper it has been assumed that neither the volumes nor values are significant. For example in 1910 nail exports of 448 cwt of total value £386 had duty repaid (‘drawback’), compared to the total nail imports of 120,464 cwt of £70,232 value.

Figure 2 shows a steady growth in nail imports from 1871 (13,793 cwt) to 1910 (120,464 cwt) – an increase of 670% over 41 years, an average compound growth of 5.4% per year. Until 1893 the main source was clearly British – whether from the United Kingdom or its (then) Australian colonies. Starting in 1893 the sources changed away from Britain to firstly Europe, then the United States of America, and then Canada. Nails from Canada were not subject to preferential rates of duty, so it would appear unlikely that American nails were being trans-shipped for export.

Table 3 provides five-yearly data from 1871 to 1910 for the unit cost of nail imports by country of origin (no data could be found for 1870). The average cost was calculated from the total import weight and cost.

Table 3: Cost per unit of nail imports – selected years

Year	Cost per unit weight of imports (£ NZ/cwt)					Average
	U.K	‘Australia’	Canada	USA	Europe	
1871	£1.37	£1.44		£0.96		£1.38
1875	£1.20	£1.47		£2.40		£1.24
1880	£0.98	£1.40		£3.86		£1.11
1885	£0.68	£0.88		£3.12		£0.78
1890	£0.65	£1.38		£2.80	£0.79	£0.76
1895	£0.54	£0.70		£2.97	£0.52	£0.64
1900	£0.77	£1.59		£0.64	£0.68	£0.69
1905	£0.72	£1.76	£0.53	£0.54	£0.58	£0.58
1910	£0.64	£1.31	£0.50	£0.54	£0.68	£0.58

Table 3 shows that the cost per unit for imports from the USA plummeted from £2.97 per cwt in 1895 to £0.64 per cwt in 1900. The consequence can be seen in Figure 2, with USA imports increasing from 4% to 52% of the total. The reason for this price drop was probably due to the establishment of the “Wire-nail Association” – a cartel of USA nail manufacturers which commenced on 1 May 1895 and lasted until 1 December 1896. It was designed to increase local prices by restricting supply.<sup>34</sup> It is likely that the constrained USA market permitted the nail manufacturers to profitably export their product elsewhere in the world.

Figure 3 shows the nail imports from 1871 to 1910 in terms of weight per head and value per head. The population count is based on the census population (including Maori) assuming a linear increase between the census years. Although there are some large swings in imported weight per head between 1871 and 1885, it then settles to a slow increase. The cost per head also settles after this time, increasing far slower than the weight imported per head, suggesting the cost benefits of the improving international nail manufacturing technology.

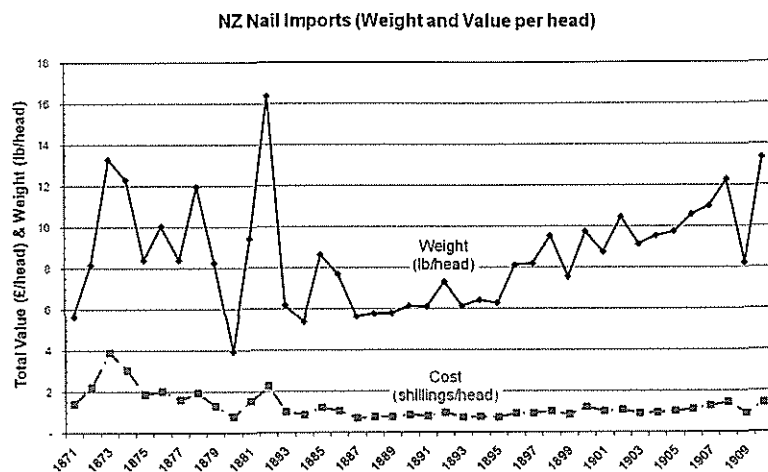

Figure 3. Nail imports per head -1871 - 1910 By Value & Weight

Use of Nails

In the early days of European settlement, timber was used for all building types – residential, commercial, industrial and agricultural. The use of nails was limited largely to fixing of boards for claddings and linings, whereas in framing there was more reliance on mechanical connections such as mortise and tenon, often with a tree-nail or wooden peg. As nails became more readily available these construction methods could change, although standard plans to permit a comparison have only been found for housing.

By 1883 settlers desiring a house could be guided by Brett’s “Colonists’ Guide and Cyclopaedia” which provided a series of four cottage designs with from four to eight rooms, requiring on average 209 lbs of nails in various sizes at an average cost of 2.4d per pound.<sup>35</sup>

For comparison, in 1883 a total of 3,352,160 lb of nails were imported (average cost 2d per pound)<sup>36</sup> – based on the Brett’s’ average, this would have been enough for some 16,100 houses. Census data shows that between the 1881 and 1886 Censuses there were an average of 3,774 houses built per year, with 69% having from three to six rooms, and 30% with more than six rooms.<sup>37</sup>

‘Nail’ Factories and Employees

As part of national censuses of manufacturing, all ‘nail’ factories were recorded. Table 4 provides results from the 1892 (actually conducted during April 1891)<sup>38</sup>; 1896 (conducted during 1895)<sup>39</sup>; 1901; 1906 and 1910<sup>40</sup> Censuses of Manufacturing, Machines & Works. Only “lead-headed nail factories” are recorded, suggesting the primary purpose was the addition of a lead-head rather than the manufacture of the base nail. No nail factories were recorded in the 1867, 1878 or 1881 Censuses.<sup>41</sup>

The 1892 Census of Manufacturing reported one ‘lead-headed nail factory’ in Canterbury (main city Christchurch) employing eight males. The 1897 Census reported three factories in Canterbury, one in Wellington and three in Auckland, employing in total ten males and two females. By 1910 there were only two factories (Auckland and Wellington), employing a total of six males.

Table 4: Lead-headed nail works 1892 – 1910

Manufacturing Census headings	1892	1896	1901	1906	1910
Location (Provincial District)					
Auckland		3		1	1
Wellington		1		1	1
Canterbury	1	3			
<b>Number of works</b>	<b>1</b>	<b>7</b>	<b>1</b>	<b>2</b>	<b>2</b>
Number of hands employed	8	12	3	6	6
Total wages paid	£227	£494	*	*	*
Approximate value of Manufactures, &c.	-	£2,834	*	*	*
Approx. value of land, buildings, machinery & plant	-	£2,325	*	*	*

\* Confidential due to small number of works

Due to the small number of works and the corresponding confidentiality limitations, financial data was only reported in 1896. The ten males received an average of £46 (NZ average £77) and the two females £15 (NZ average £30) in wages for the year- clearly not a high paying industry.<sup>42</sup>

It is possible that nail manufactories also existed, although information has only been found on the horse shoe nail factory operated by Mr. J. Hill of Christchurch and noted in the report of the 1880 Christchurch Industrial Exhibition.<sup>43</sup> Opened in 1880 it made horse shoe nails<sup>44</sup>, and was still in existence in 1883 when it trialled the use of New Zealand made iron which reportedly “successfully withstood all the tests usually applied to the best nail rod.”<sup>45</sup>

Nail manufacture could also be a secondary activity, as was the case for the Southern Cross Iron Works (see below). The possibility that the specialised employees recorded their involvement with nails was explored through inspection of the 1893 Electoral Roll (the first election in the world with universal suffrage). Only three adult males reported occupations including “nail” (two in Christchurch, one in Auckland) and only one with “lead” but he was a “leadpipe maker.”<sup>46</sup> In Christchurch, Alfred Robb reported his occupation as “nail maker” (see below) while Richard Thomas Mallet was recorded as a “nail factory employee”. In Auckland, Alfred Norwood was listed as a “nail maker” and lived close to the Southern Cross Iron Works (see below).

Inventors & Manufacturers<sup>36</sup>

The creation of new and improved types of nails lead Victorian inventors to bring forth a range of innovative ideas and patents. For the period from 1 January 1883 to 31 December 1909, 41 patent applications relating to nails have been found in the pages of the NZ Government Gazette<sup>47</sup> - this compares to a total of 26,210 patent applications over this period.<sup>48</sup> In the following text, the patent numbers are given in braces { }.

The inventor’s occupation was given in 32 of the 41 nail patent applications: 13 were plumbers; seven engineers; and the rest from a variety of trades and professions. Thirty patents were from New Zealand inventors, eight were from Australian based inventors and two from England.

The majority (25) of the applications were for corrugated iron lead headed roofing nails. It was not until 1891 that David Estler Blacke, Manager of the Austral Nail Company (Limited) of South Melbourne patented an “improved wire nail making machine” {Patent number 5,201}<sup>49</sup> – prior to then the patents concerned only the addition of a lead ‘cap’ to the nail.

Lead-head nail manufacture requires skill, whether produced by hand or machine. It was essential to ensure that the lead cap sat properly on the nail, sealed tightly onto the roof and would not be damaged by the hammer blows of roofers. Although many patents were taken out for such nails, this did not stop local plumbers producing their own versions. Even in the twentieth century the plumber would use

leftover scrap lead (which had already been paid for by a client) and the apprentice's spare time to make their own lead-headed nails, allowing them to undercut the prices of the 'legitimate manufacturer'.<sup>50</sup>

Table 5: Early New Zealand nail manufacturers

Date	Business	Patent	Location	Nail Type or Description
1883	Samuel Parker	877	Auckland	Galvanized lead-head roofing
1883	Joseph Venables	915	Christchurch	Tin wired, solid lead-head roofing
1884	Alfred Robb & William Stokes	1,152	Christchurch	Lead-head roofing
1884	John Sinclair	1,165	Christchurch	'Acme' & 'Mushroom Head' Nail
1885	Henry Davenport	1,643	Wellington	Perfect fitting solid-headed arch-shaped roofing nail
1890	Ballinger Brothers	-	Wellington	Roofing
1890	George McCaul	3,489	Auckland	Composition-metal head roofing
1894	John Alexander	-	Wellington	Lead-head nails
1897	Horace Thompson	9,436	Christchurch	Split nail
1897	D. Nicolson & Co	-	Dunedin	'Varnish and wire nail factory'
1906	Crown Nail Company	-	Dunedin	Lead-head roofing
1909	Auto Machine Manufacturing Co. Ltd.	-	Auckland	Unspecified - wire nail

Table 5 provides a summary of the earliest New Zealand nail manufacturers for which information has been found. The date refers to the earliest reference to nail making, whether in a commercial directory, a newspaper advertisement, the issuing of a patent or investigating the purchase of manufacturing machinery. The following sub-sections explore each of these manufacturers.

**Southern Cross Iron Works:**

Samuel Parker, an English plumber, set up his galvanising and corrugated iron rolling plant in Auckland in 1886.<sup>51</sup> Three years earlier, on 30 July 1883, he had applied for a patent {877} for his 'Galvanized lead-headed nail'.<sup>52</sup> Parker's invention was to make use of a galvanized, rather than a non-galvanized, nail. He claimed the advantage "that it makes a more durable roof as the present lead-headed nails not being galvanized rust and corrode away, thereby causing the iron to get loose and so cause the roof to leak." The patent drawing shows a wire nail with a hemispherical lead cap<sup>53</sup> (see Fig. 4).

In 1884 John Sinclair, engineer, patented {1165} his "Improvement in nails for roofing purposes by the combination of the nail and washer in one piece, so prepared as to be incorrodible {sic}, and called the 'Acme' and the 'Mushroom Head' Nail respectively"<sup>54</sup> (see Fig. 5). The 'Acme' was wire nail fitted with a washer that stuck to the nail head as it was galvanized, acting as a rain hat to the hole the nail made in the roofing<sup>55</sup> - the forerunner of today's springhead nail.

Parker's Southern Cross Galvanized Iron Manufacturing Company (Limited) advertising for the 1898 Auckland Exhibition reported it was manufacturing "the celebrated patent 'Acme' roofing nail, spouting, ridging, corrugated iron tanks and lead-headed nails".<sup>56</sup> The company won prizes for corrugated roofing iron and galvanized iron buckets, but there was no prize for their nails.<sup>57</sup>

**Joseph and Philip Venables:**

Joseph Venables, a plumber, was first listed in the *Wises New Zealand Post Office Directory* as a 'nail maker' in 1900 at '240 South Belt, Christchurch'.<sup>58</sup> The Venables family first appeared in *Wises* directory in 1896 as living in "South Belt, Christchurch", where Joseph was a plumber and his son Philip

Henry was listed without any trade.<sup>59</sup> In the 1893 electoral roll for the Christchurch electorate, both Joseph and Philip Venables were both enrolled as plumbers.<sup>60</sup> From 1900 to 1908 (at 240 Moorhouse Ave, Christchurch) Joseph Venables was the only New Zealand nail manufacturers listed in *Wises*.<sup>61</sup> Joseph Venables died on 5 Jan 1914<sup>62</sup> and the business was promptly taken over by his son Philip<sup>63</sup>, suggesting he had already been involved for some time. The business ultimately became P.H. Venables Ltd.

Joseph Venables applied for a patent on 13 September 1883 {915} for "Tin Wired Nails with solid lead-heads and washers". His invention first tinned the nail and then cast the lead-head on to it, making it solid and not liable to separate from the nail when being driven. It was claimed that the "wire nail makes a smaller hole in the iron than the ordinary galvanised nail. The solid head prevents leakage. The combination saves time in dispensing the necessity of threading washers required in the use of the ordinary galvanised nail and can be supplied at less cost"<sup>64</sup> (see Fig. 4). In 1899 Joseph Venables again applied for a patent for "An improvement in the manufacture of lead-headed nails, and apparatus for employment in connection therewith" {11,384}<sup>65</sup>, but this application lapsed in 1900.<sup>66</sup>

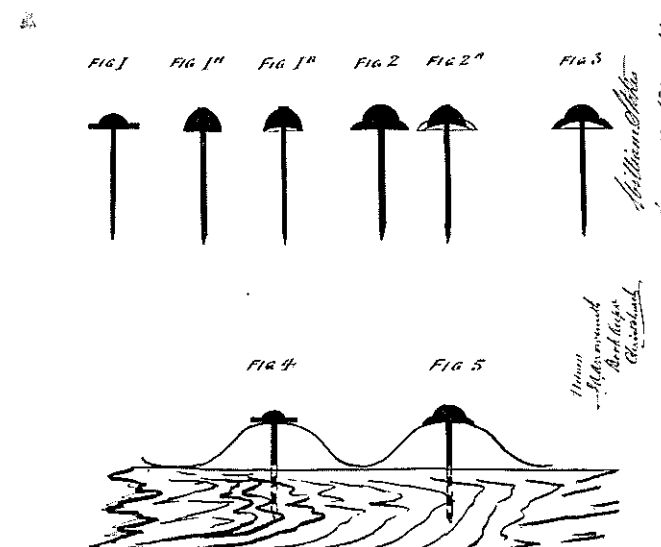

Figure 4. Alfred Robb & Williams Stokes' 1890 patent drawing of roofing nails {Patent 1,152} 1 - Venables; 1a & b - Parker; 2a & b, 3 - Stoke & Robb "cupheaded self adjusting roofing nail"; 4 - Venables "without being dressed down"; 5 - Stoke & Robb "requiring no dressing whatever"

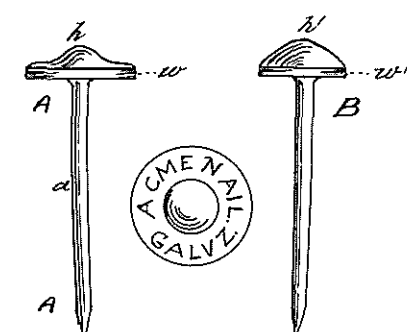

Figure 5. John Sinclair's 1884 "Acme" and "Mushroom Head" Nails {Patent 1,165}

**Henry Davenport:**

A British trained plumber, Henry Davenport started business in Wellington in about 1874<sup>67</sup>, not in 1864 suggested by Thomson.<sup>68</sup> In 1885 he patented {1,643} a "Perfect fitting solid-headed arch-shaped roofing nail"<sup>69</sup> (see Fig. 6). The patent lapsed in 1891 through non-payment of the renewal fee.<sup>70</sup>

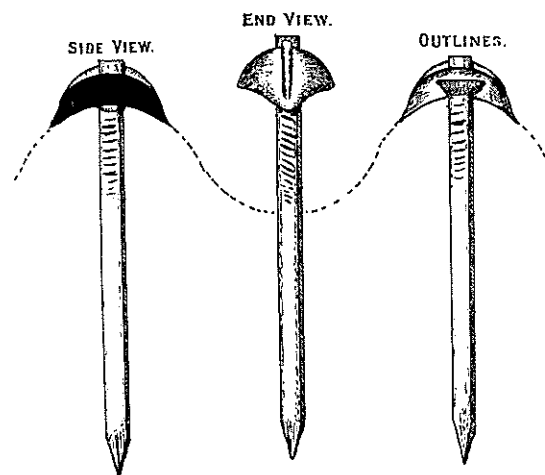

Figure 6. Henry Davenport's 1885 Perfect Fitting solid headed arch-shaped roofing nail {Patent 1,643}

In 1890 Davenport was advertising his own lead-headed nails:

"H. Davenport & Son, Manufacturers of Patent and Other Lead-Headed Roofing Nails, Will Indemnify all buyers of their Cup-headed Self-adjusting Nails in any proceedings Mr. Stokes may take against buyers."<sup>71</sup>

William Stokes, who had patented his design in 1887 (see below) actively defended his nail patent – his advertisement appearing in the same column on the same dates:

"Anyone purchasing or selling self-adjusting lead-headed roofing nails without "Stoke's (sic) Patent" stamped on each head will be prosecuted."<sup>72</sup>

Court action followed in June 1892, but the High Court decided the patent had not been infringed. Stokes then went to the Court of Appeal which reversed the lower court decision and decided that the patent had been infringed, awarded costs, any profits and a 'perpetual injunction'.<sup>73</sup>

Even after the court case, H. Davenport and Son continued to actively promote their lead-headed nails. In February 1894 they claimed "superior Leadheaded {sic} Nails, with firm stamped heads" which "took second prize at the Dunedin Exhibition"<sup>74</sup>, while in September 1894 they claimed an output of "50 tons per year"<sup>75</sup> (1 ton = 20 cwt = 1,016 kg) and in February 1896 that they "have the only machines in the colony that Mould and Stamp Lead-headed Nails, which makes heads solid and firm thus making no loose heads, which are the cause of so much trouble and expense."<sup>76</sup>

Davenport's business continued to at least 1911, when it was advertising for "Boys, 14 to 16, for nail factory; good wages paid. Apply 216 Tinakori-road".<sup>77</sup>

**Alfred Robb and William Stokes:**

It is likely Robb & Stokes of Christchurch, were the earliest New Zealand manufacturers of wire nails from about 1887.

Alfred Robb and Williams Stokes, carpenters of Sydenham, Christchurch, were awarded a patent on 3 July 1884 and amended on 28 August 1890 {1,152} for a "Cup-headed, self-adjusting tinned-wire roofing-nail requiring no washer".<sup>78</sup> This nail differed from other lead-head nails in the "cupping of the head with a cup shaped flange which being of soft metal such as lead causes the self adjustment of the same to the corrugated iron when driven down thereby making a perfect fit which renders the same perfectly water tight". Figure 4, taken from the patent documentation, compares their nail to other patented nails including the Venable nail "which requires dressing down" (i.e. the lead being hammered down onto the iron to form a seal) and the Parker nail "which by reason of the solidity of the head does not adjust itself".<sup>79</sup>

Robb & Stokes' nail was also patented in pre-Federation Victoria (Patent 3862) and registered in New South Wales (Patent 84/11864). On 7 January 1886 Robb mortgaged his ownership in the patent to Stokes for £494 7s 6d, to be paid in six unequal instalments from 1 July 1887 to 4 January 1889. On 14 June 1887 Stokes then sold the mortgage to Edward Ashby, a Christchurch accountant.<sup>80</sup>

On 8 October 1886, Robb wrote to the Customs Department in Christchurch inquiring if there was a tariff on the machinery to make wire nails.<sup>81</sup> This letter was copied to Wellington where it was received on 11 October and on 19 October the reply letter stated that there was no tariff.<sup>82</sup> The publication on 17 December 1886 of a summary list of tariff decisions stated that nail making machinery was to be admitted free of duty.<sup>83</sup> If a previous nail making machine had been imported, then a new decision would not have been required, suggesting that this decision was for the first wire nail machine to be imported into New Zealand.

This is supported by Stokes appearance as a 'nail manufacturer' before the 1895 Tariff Commissioners, where he stated he had been 'ten years in business in Christchurch', suggesting the business had been profitably making lead-headed nails for some years before importing wire nail making machinery.<sup>84</sup> At his appearance he also claimed to employ six boys and requested "the duty on wire nails to be increased from 2s to 7s per cwt" – which the newspapers note would "add 1d per lb to an article of everyday use."<sup>85</sup> Stokes reported his production was £100 per month and he argued that the cost of imported nails was so low it was not worth his while to continue make wire nails<sup>86</sup> – £1,200 per year was about 5% of the £25,965 value of nail imports in 1895.

"Stokes, William Christchurch" also had the first listing for a "nail maker" in the *Wises New Zealand Post Office Directory* from the 1887 edition. This listing continued for five issues until 1896<sup>87</sup> – no further advertisements have been found.

Stokes and Robb (and later Ashby) defended their patent on "10 or 12 different occasions" against the Patent Office issuing other similar patents.<sup>88</sup> They also made use of the courts to protect their patent, as already noted, but more interestingly in 1890 against George McCaul (see below). In this case the jury found against them, on the grounds that Parker's cup-shaped lead-headed nail, had been manufactured in Auckland before their nail was patented. The judge, Mr Justice Connolly, was of the opinion that the specifications were good, notwithstanding this circumstance.<sup>89</sup>

**Ballinger Brothers and George McCaul:**

Stokes was joined in Wises Directory listing of nail makers in 1890-1 by 'Ballinger Brothers' of Wellington and Petone, and 'George McCaul' of Auckland, who were both listed as manufacturers of corrugated iron and spouting, and also roofing nails – although they both only appeared in that year and in no following issues.<sup>90</sup> "Ballinger J." had first appeared in 1883-4 Wises Directory listed as a plumber in Wellington.<sup>91</sup> In 1894 Thomas Ballinger was advertising his "Lead-head Nail Manufactory".<sup>92</sup>

George McCaul patented "McCaul's Composition-metal headed nail" {3,489} in 1889<sup>93</sup> (see Fig. 7). In the 1890 Wise's directory McCaul's works claimed their nail as being "acknowledged by architects and builders to be the best roofing nail ever manufactured in the southern hemisphere".<sup>94</sup>

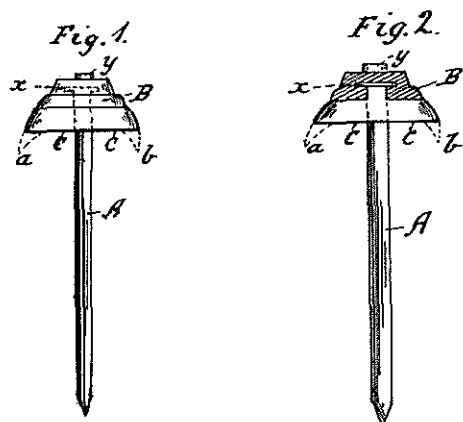

Figure 7. George McCaul's 1890 Composition-metal head roofing nail {Patent 3,489}

**John Alexander:**

John Alexander advertised in the *Wellington Evening Post* of 25 June 1894 that he was a "Plumber, Gasfitter, Bell-hanger, Sanitary and Hot Water Engineer, Lead-headed Nail Manufacturer" His advertisement appeared in the classified advertisements section daily for the next two months, until 25 August 1894 when they stopped.<sup>95</sup> No later advertisements have been found.

**Horace Thompson:**

Horace Thompson, a pianoforte tuner of Christchurch, patented his 'split nail' {9,436} in 1897.<sup>96</sup> The invention was a "nail having a division extending lengthwise from the outer extremity or point to within a short distance of the top or head, so that as the nail is driven into the wood it will divide into two parts, each spreading in an opposite direction, thus obtaining a better fit and firmer hold than with an ordinary nail"<sup>97</sup> (see Fig. 8).

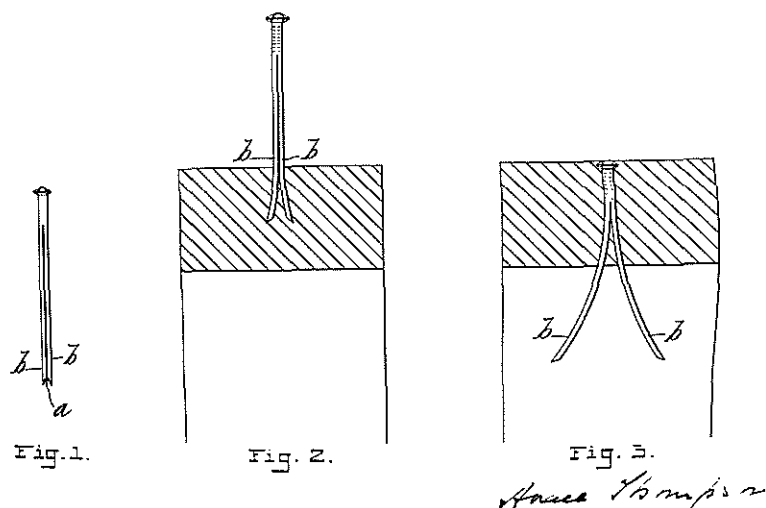

Figure 8. Horace Thompson's 1897 Split Nail {Patent 9,436}

Thompson attempted to commercialise his invention, but perhaps unsurprisingly given the inherent impracticality of the invention, five months later the "Split Nail Company (Limited)" was voluntarily wound up<sup>98</sup> with the patent lapsing the following year.<sup>99</sup>

**David Nicolson:**

This short lived 1897 business appears to have been the first New Zealand wire nail manufacturer not based around the production of lead head nails.

In 1894 David Nicolson, "wire-drawer and wire mattress maker" of Dunedin, was awarded two patents – one for the weaving of a three and five-ply wire mattress {6,695}; and one for "Nicolson's spiral wire- woven floor cloths for kilns and drying rooms" {6,705}.<sup>100</sup> The patent application for the wire mattress lapsed the following year.<sup>101</sup>

David Nicolson had started in business as a manufacturer of wire mattresses in May 1894, presumably based on his patent. In July 1896 he sold his business (D. Nicolson & Co.), the factory, and the leasehold on the land to William Parker and Co. for £860, £350 in cash and the rest as promissory bills. On 18 August 1896, Nicolson's patent number 6,705 for the wire floor cloth was licensed for four years to "William Parker of Dunedin, Accountant".<sup>102</sup> Mr Parker was a long term resident of Dunedin, and been employed "in a position of trust by Kempthorne Prosser and Co. for 20 years".<sup>103</sup>

Nicolson was first listed in the 1896 Stones directory as a 'wireworker'<sup>104</sup> but the following year D. Nicolson & Co is listed as operating a 'varnish and wire nail factory' in Willis St, Dunedin.<sup>105</sup>

During 1896 the Dunedin firm of Paterson & Barr, ironmongers, agreed to import 20 tons of various sizes of nail making wire to be turned into nails for them to sell, while Nicolson "commenced to get his machinery in order". The wire arrived in January 1897 but Nicolson only delivered about 24 cwt of finished nails.<sup>106</sup> Although the reasons for this failure to deliver have not been found, it appears the nail making machinery was working, as 'W.H. Scott, Mechanical Engineer' undertook "Repairs to Cams of Nail machine £0 12s 6d" on 5 March 1897.<sup>107</sup>

David Nicolson was adjudged bankrupt on 24 April 1897.<sup>108</sup> Unusually the bankruptcy took considerable time to be processed, with nine separate news reports during May 1897.<sup>109</sup> It appears to have been most unhappy, with blame being placed on Parker who had not honoured the promissory notes with which he purchased the business. The highest tender received for the leasehold, plant and stock was £339. This was not accepted, and after auction on Saturday, 22 May 1897, it was sold to Mr C.W. Harvey for £420.<sup>110</sup> No evidence has been found of the business continuing to manufacture nails.

The bankruptcy valuation list for David Nicolson includes:

- "1 large nail machine £40" and
- "4 small nail machines £120"

Thus £160 out of a total plant valuation of £660 6s 7d was in machinery to produce nails. The factory stock was valued at £247 1s 8d, but included no wire or unfinished nails, although it includes a range of raw materials for the manufacture of varnish.<sup>111</sup>

David Nicolson is again listed (but no company) in the Stones local business directory in 1898 as a wireworker<sup>112</sup>. He was released from bankruptcy on 23 August 1898.<sup>113</sup> No further evidence has been found of him in Dunedin either in business directories<sup>114</sup> or local electoral rolls.<sup>115</sup>

Proceedings to put W. Parker & Co. into receivership were commenced on 12 October 1897<sup>116</sup> and William Parker was made bankrupt on 4th December 1897, paying on 5 shillings in the pound (25%).<sup>117</sup>

**Crown Nail Company:**

The 'Crown Nail Co. Ltd, Fredk Beadle, mgr' was first listed in *Stones Otago & Southland Directory* in 1906, located at 10a Great King Street.<sup>118</sup> The Crown Nail Co. Ltd. continued to be listed in the local Stones directory to 1910<sup>119</sup> but only appears in the Wisers Directory for the 1908 year – the only other

nail business being that of Joseph Venables.<sup>120</sup>

Frederick Beadle died in Dunedin on 31 July 1917 and the probate records his occupation as “lead headed nail maker”. The business of Crown Nail Company was left to his nieces and nephews, and was sold realising £174 12s 10d.<sup>121</sup>

#### The Auto Machine Manufacturing Company:

The Auto Machine Manufacturing Company Limited started life in Auckland on 10 May 1909 – formed by the family of Mr William Squire Fowler for the purpose of “putting on the market in Auckland or elsewhere a large machine capable of making one length of drawn pipe at one operation”.<sup>122</sup> Although the machine was not ultimately successful, even during its first year the company was interested in a wider market. The company’s name was an abbreviation of the word ‘automatic’ – that being the type of equipment the company was to deal with.

The company archives hold a letter dated 9 October 1909 from The National Machinery Co. of Tiffin, Ohio U.S.A. responding to a request for information on nail making machinery and welcoming a future visit from the company.<sup>123</sup> However, the company records suggest it was not until 1913 that the recommendation was made to the Board of Directors for the company to purchase a nail making machine.<sup>124</sup> The company merged with P.H. Venables in 1941.<sup>125</sup>

#### Conclusion

“A typical small cottage had two small rooms under a gable room, with a frame of studs and plates – the studs mortised into the plates to reduce the need for nails which were still an expensive imported item. In the 1840s and 1850s many nails were still hand-made, although mass production had been possible since patents in 1810 in America and 1827 in England. In the past other fixings such as wooden pegs or even sheep’s bones had been used, but the timber-framed and weatherboarded house of the 1840s onwards depended on iron nails for its strength and ease of construction.”<sup>126</sup>

The earliest nails in New Zealand were brought from Europe by explorers such as Captain James Cook. Once European migration commenced, in order to create European style wooden housing it was necessary to import European style nails. In the early years these were hand-made, shifting to cut nails and then towards the end of this period to wire nails.

Although it is not possible to state with any certainty whether hand-made wrought iron nails were made in the early years of European settlement, it can be expected that these were within the skills of many, if not all, blacksmiths. Forged horseshoe nails were being made in Christchurch in 1880.

New Zealand in the 1800s and early 1900s was an innovative society, shown not only by the number and range of patents or different types of nails, but also in the way the industry developed. The earliest New Zealand patent for a lead-headed roofing nail dates from 1883, although the first commercial directory listing for a ‘nail manufacturer’ or ‘nail maker’ was not until 1887.

Analysis of the volume of imported nails compared to the construction of new houses suggests imports were more than adequate. The solitary manufacturer (Robb & Stokes) for which production value has been found after an extensive review of trade directories, newspapers, patents and official source, produced about 5% of the 1895 nail imports – suggesting it is highly unlikely that a larger manufacturer existed. This does not close the possibility that a smaller nail manufacturer remains to be found in the period to 1910.

Nail making was never a major industry in New Zealand – unlike USA or England where the manufacturing scale resulted in a sizable collection of records for later historians to analyse.<sup>127</sup> Few New Zealand nail making businesses continued into the twentieth century, and even then seldom held (or

valued) detailed records of their earliest days. The small industry size meant only limited official statistics were published; while the commodity nature of nails limited any advertising to trade publications or company specific advertising sheets or catalogues, none of which appear to have survived in modern libraries or archives. Together these have resulted in the disappearance of the nail industry from New Zealand’s industrial history.

It has been shown that although lead-head and other roofing nails were manufactured in New Zealand from the 1880s to the end of the period covered by this paper, evidence has been found linking only one of these manufacturers to the production of wire nails. Alfred Robb and Williams Stokes, of Christchurch, imported wire nail making machinery and then manufactured wire nails by about 1887, although advertising for the business only continues until 1896.

The first non-lead head nail manufacture of wire nails was in Dunedin in 1897, by David Nicolson and his business D. Nicolson & Co. (later William Parker and Co.). This business was short lived – not apparently due to the product, but rather to the financial failure of the major investor. No evidence has been found to suggest the plant was re-established following the second receivership in 1897. It would appear that the next business to manufacture wire nails started investigation into the import of an American wire nail making machine in 1909 was the Auckland based Auto Machine Manufacturing Company Limited. This came to fruition in 1913.

Although only a minor part by cost of a timber building, iron and latter steel nails have played a critical role in the development of timber buildings in modern New Zealand. British nails may have been supplanted by American sourced nails in the 1890s, but the global red swath of the British Empire has remained, coloured by the rust of iron and steel nails. The ready availability of imported low cost iron nails supported the rapid expansion of European settlements into the New Zealand countryside, and ultimately led to today’s landscapes of timber buildings.

*Correspondence:* Nigel Isaacs, School of Architecture, Victoria University of Wellington, PO Box 600, Wellington, New Zealand 6140. [nigel.isaacs@vuw.ac.nz](mailto:nigel.isaacs@vuw.ac.nz)

#### Acknowledgements

The help and support of current and past nail makers is much appreciated – Ned Niha of NZ Nail Industries Ltd, Ken Wheeler (retired) of Pearson, Knowles & Rylands Bros. N.Z. Ltd, Max Warwick (retired) & Alan Malaquin of Hurricane Wire Products Ltd. Thanks to Dorothy Neilson of Fletcher Challenge Archives, Jeremy Salmond and Peter Reed of Salmond Reed Architects Limited and William Cottrell for their reviews and support, and for general assistance to David Kernohan, Dr Robin Skinner and Dr Christine McCarthy of the School of Architecture, Victoria University of Wellington.

#### References

1. *North Otago Times* (1 July 1882), p. 2.
2. *Auckland Industrial and Mining Exhibition : opened December 1st, 1898 : official handbook and catalogue*. Auckland, N.Z. : Geddis and Blomfield (1898), p. 61.
3. Arthur Cleave Publishing Co. *Industries of New Zealand (illustrated) : an historical and commercial review : descriptive and biographical, facts, figures and illustrations : an epitome of progress : business men and commercial interests*. Auckland, N.Z. : Arthur Cleave Publishing Co (1898) p. 246-8.
4. J. Salmond, *Old NZ Houses 1800-1940*. Auckland : Heinemann Reed (1986), p. 105.
5. W. Cottrell, *Furniture of the New Zealand colonial era : an illustrated history, 1830-1900*. Auckland : Reed (2006), p. 429.



6. S. Thomson, *Wrinkly Tin – the story of corrugated iron in New Zealand*. Wellington: Steele Roberts (2005), p. 107.
7. W.J. Phillips, *Maori Houses and Food Stores*. Dominion Museum Monograph No. 8 Wellington : Government Printer (1952).
8. *Ibid.* p. 40.
9. S. Nathan 'Mining and underground resources' (updated 30-Jan-2007), *Te Ara - the Encyclopedia of New Zealand*. [www.teara.govt.nz](http://www.teara.govt.nz) Accessed 4 June 2007.
10. Captain W.J.L. Wharton (ed.) *Captain Cook's Journal During His First Voyage Round The World Made In H.M. Bark "Endeavour" 1768-71 - A Literal Transcription Of The Original Mss. With Notes And Introduction*. London : Elliot Stock, 62 Paternoster Row (1893) (Accessed electronically – Project Gutenberg EBook #8106 [www.gutenberg.org](http://www.gutenberg.org)).
11. Wharton. Entry for Tuesday, 6 June 1769.
12. Wharton. Entry for Tuesday, 19 June 1770.
13. M.F. Lloyd Pritchard *An Economic History of New Zealand* Auckland: Collins (1970), pp. 36-7.
14. Data sources for appropriate year : *Census of the Colony of New Zealand* Wellington : Government Printer.
15. *Results of a census of the Colony of New Zealand, taken for the night of the 28th March, 1886*. Wellington : Government Printer (1887).
16. *New Zealand Gazette* (2 May 1840), Vol. 1 Issue 4, p. 3.
17. Examples obtained electronically from Papers Past website – [paperspast.natlib.govt.nz](http://paperspast.natlib.govt.nz), or from copies held in National Library of New Zealand.
18. *New Zealand Gazette* (18 April 1840), Vol. 1 Issue 2, p1.
19. Richard Jones 'J.J. Cordes Limited' *TATHS Newsletter* No 90 (Autumn 2005), pp. 23-24.
20. R V J Varman *Bricks and Nails. Building Materials as Criteria for Dating in Sydney and Environs form 1788* PhD Thesis, University of Sydney 1993 p. 158.
21. *Daily Southern Cross* (8 July 1848), p1.
22. *New Zealand Spectator and Cook's Strait Guardian* (8 Aug 1849), p. 2.
23. *Nelson Examiner and New Zealand Chronicle* (24 Oct 1857), pp. 1 & 4.
24. Chris How 'The American Cut Nail', in Miles Lewis, ed. *The Pacific Connection – Proceedings of a seminar at the University of Melbourne, 19-22 February 2009* (2009), pp.74-88.
25. *Daily Southern Cross* (16 Dec 1868), p. 6.
26. G.T. Chapman *Chapman's Auckland directory (commercial and professional) of the city of Auckland & suburbs and principal towns & villages of the Province 1873*. Auckland : G.T. Chapman (1873), p. 446.
27. *North Otago Times* (17 Jun 1895), p. 1.
28. Priess, P. 'Wire Nails in North America' *Bulletin of the Association for Preservation Technology*, Vol. 5, No. 4 (1973), pp. 87-92.
29. Priess.
30. Royal Commission for the Exhibition of 1851. *Reports by the juries on the subjects in the thirty classes into which the exhibition was divided*. London : Printed for the Royal Commission for William Clowes & Sons, 1852. (1852), pp. 194-205.
31. Varman *Bricks and Nails* p. 164.
32. Edgerton, Charles E. 'The Wire-Nail Association of 1895-96', *Political Science Quarterly*, Vol. 12, No. 2 (Jun., 1897), pp. 246-272.
33. New Zealand Government *Statistics of the Colony of New Zealand for the Year ...* (individual years consulted 1862 to 1910) Wellington : Government Printer.
34. Edgerton, Charles E. 'The Wire-Nail Association of 1895-96', *Political Science Quarterly*, Vol. 12, No. 2 (Jun., 1897), pp. 246-272.
35. Thomson W Leys (editor) *Brett's colonists' guide and cyclopaedia of useful knowledge*. Auckland : H. Brett, Evening Star Office (1883 ) (edition use: Christchurch : Capper Press 1980 facsimile reprint).
36. *Statistics of the Colony of New Zealand for the year 1883*. Wellington : Government Printer.
37. *Results of a census of the Colony of New Zealand, taken for the night of the 3rd of April, 1881* Wellington : Government Printer (1881).  
*Results of a census of the Colony of New Zealand, taken for the night of the 28th March, 1886*. Wellington : Government Printer (1887).
38. *New Zealand Gazette* (14 Jan 1892), pp. 64, 67.
39. *New Zealand Gazette* (25 Jan 1897), pp. 194-5, 198-9.
40. *Statistics of the Dominion of New Zealand for the Year 1910*. Wellington : Government Printer (1911), p. 429.
41. *Statistics of New Zealand for 1867, 1878, 1881* Wellington : Government Printer.
42. *New Zealand Gazette* (21 January 1897) "Supplement: Census 1896 – Manufactories, Works, &c."
43. W. Cottrell, *Furniture of the New Zealand colonial era : an illustrated history, 1830-1900*. Auckland : Reed (2006), p. 428.
44. *West Coast Times* (22 June 1880), p. 2.
45. *Otago Witness* (2 June 1883), p. 9.
46. New Zealand Society of Genealogists [NZSG], *1893 Electoral Roll*. Auckland : NZSG (2004).
47. *New Zealand Gazette Archive*. [Electronic resource] Wellington : LexisNexis .
48. Count based on Archives New Zealand/Te Rua Mahara o te Kawanatanga: Series ABPJ 7396 W3835.
49. *New Zealand Gazette* (1 Oct 1891), p. 1082.
50. Department of Industries & Commerce *Visits to Factories - 14 Dec 1928, Lino Nail Company*. Archives New Zealand IC1 File 19/105 Part 1.
51. G. Chapple, D. Mitchell, J. Maynard and W. Viscoe *Corrugated Iron in New Zealand*. Wellington: A.H. & A.W. Reed (1983), p. 27.
52. *New Zealand Gazette* (2 Aug 1883), p. 1084.
53. S. Parker *Galvanized lead-headed nail* Archives New Zealand/Te Rua Mahara o te Kawanatanga, Wellington Office: ABPJ 7396 W3835 877.
54. *New Zealand Gazette* (24 Jul 1884), p. 1170.
- J. Sinclair *Improvement in nails for roofing purposes by the combination of the nail and washer in one piece, so prepared as to be incorrodible, and called the "Acme" and the "Mushroom Head" Nail respectively*. Archives New Zealand/Te Rua Mahara o te Kawanatanga, Wellington Office ABPJ 7396 W3835 1165.
55. Chapple et al., pp. 27-8.
56. Geddis and Blomfield *Auckland Industrial and Mining Exhibition : opened December 1st, 1898 : official handbook and catalogue*. Auckland, N.Z. : Geddis and Blomfield (1898).
57. *Exhibition Numbers of the NZ Herald & Weekly News* 1898. p37.
58. *Wises New Zealand Post Office Directory 1900* [Wises] Dunedin : H. Wise & Co. N.Z., Ltd.
59. *Wises Directory 1896-7* .
60. NZSG *1893 Electoral Roll*.
61. *Wises Directory* (consulted 1900-1908 inclusive).
62. Joseph Venables *Probate*. Archives New Zealand/Te Rua Mahara o te Kawanatanga, Wellington Office, Wellington. Reference: AAOM 6029 W3265 16170/1914.
63. *Stones Canterbury, Nelson, Marlborough & Westland Directory 1915* Dunedin : Stone, Son & Co.
64. J. Venables *Tin Wired Nails with solid lead-heads and washers*. Archives NZ ABPJ 7396 W3835 915.
65. *New Zealand Gazette* (2 March 1899), p. 533.

66. *New Zealand Gazette* (16 August 1900), p. 1566.
67. 'Plumbers Licences' *Evening Post* (12 Jan 1897), p. 2.
68. Thomson, p. 107.
69. *New Zealand Gazette* (10 Dec 1885), p. 1417.  
Archives New Zealand/Te Rua Mahara o te Kawanatanga, Wellington Office ABPJ 7396 W3835 1643
70. *New Zealand Gazette* (2 April 1891).
71. *Evening Post* (22 July 1890), p.3.
72. Both Davenport & Stokes advertisements were repeated on the same page in the *Evening Post* on 22, 23, 24 & 26 July 1890.
73. *Evening Post* (18 Feb 1893), p. 2.
74. *Evening Post* (e.g. 10 Feb 1894) p. 3.
75. *Evening Post* (e.g. 14 Sep 1894), p. 3.
76. *Evening Post* (e.g. 1 Feb 1896), p. 3.
77. *Evening Post* (26 August 1911), p. 1.
78. *New Zealand Gazette* (10 Jul 1884), p. 1113.
79. A. Robb and W. Stokes *Cup-headed, self-adjusting tinned-wire roofing-nail requiring no washer* Archives New Zealand/Te Rua Mahara o te Kawanatanga, Wellington Office: ABPJ 7396 W3835 1152.
80. A. Robb and W. Stokes *Deed of Mortgage between Alfred Robb and William Stokes* Archives New Zealand/Te Rua Mahara o te Kawanatanga, Wellington Office: ABPJ 7396 W3835 1152.
81. *Registers of Inwards Letters 1883-1888* (Archives New Zealand/Te Rua Mahara o te Kawanatanga, Wellington Office Wellington (Reference: ACIF 16476 C2 5) Letter reference 86/762: letter received 11 Oct 1886 from A Robb, Residence Christchurch.
82. *Customs Outwards Letter Book - September 1886-May 1887* (Archives New Zealand/Te Rua Mahara o te Kawanatanga, Wellington Office Wellington: ACIF 16478 C4 29) – page 127, letter dated 19 October 1886.
83. *Otago Witness* (17 Dec 1886), p.19.
84. *Appendix to the Journals of House of Representatives 1895 V3 H – Miscellaneous H-2 Report of the Tariff Commission* (Wellington 1895) Christchurch – Second Sitting, Monday 18th March 1895 p. 261.
- See also: *West Coast Times*, 13 August 1895, p. 4.
85. *West Coast Times* (13 Aug 1895), p. 4.
86. *Appendix to the Journals of House of Representatives 1895 V3 H. – Miscellaneous. H-2 Report of the Tariff Commission. Christchurch – Second Sitting, Monday 18th March 1895* Wellington :Government Printer p.261.
87. *Wises Directory* (consulted 1887-8 to 1896-7 inclusive).
88. 'All About Nails' *Evening Post* (16 June 1892), p. 3.
89. W.J.C. Stokes and E.C. Ashby *Papers "requiring C.J.A. Haselden of Wellington (Patent Officer) to attend as witness & file deposition within 17 days"*. Archives New Zealand/Te Rua Mahara o te Kawanatanga, Wellington Office: ABPJ 7396 W3835 1152.
90. *Wises Directory 1890-1*.
91. *Wises Directory 1883-4*.
92. *Evening Post* (19 Feb 1894), p. 3.
93. *New Zealand Gazette* (17 Jan 1889), p. 45.
- McCaul, George 1889 McCaul's Composition-metal headed nail Archives New Zealand/Te Rua Mahara o te Kawanatanga, Wellington Office ABPJ 7396 W3835 3489.
94. *Wises Directory 1890-1*.
95. *Evening Post* (25 Jun 1894 to 25 Aug 1894), p. 3.
96. *New Zealand Gazette* (15 Apr 1897), p. 908.
97. H. Thompson *An invention for a divided or split nail* Archives New Zealand/Te Rua Mahara o te Kawanatanga, Wellington Office: ABPJ 7396 W3835 9436.
98. *New Zealand Gazette* (23 Sept 1897), p. 1713.
99. *New Zealand Gazette* 13 Oct 1898), p. 1653.
100. *New Zealand Gazette* (15 Mar 1894), p. 435, see also *Otago Witness* (22 Mar 1894), p. 20.
101. *New Zealand Gazette* (5 Sept 1895), p. 1419.
102. *New Zealand Gazette* (20 Aug 1896), p. 1350.
103. 'Creditors Meetings – re. David Nicolson' *Otago Daily Times* (3 May 1897), p.4.
104. *Stone's Otago & Southland Commercial Municipal & General Directory 1896* [Stone's Otago] Dunedin : Stone, Son & Co.
105. *Stone's Otago Directory 1897*.
106. Paterson and Barr *Letter to Official Assignee, Dunedin dated 19 May 1897*. Archives New Zealand/Te Rua Mahara o te Kawanatanga, Wellington Office Ref: DAAD D442 22e 164.
107. W.H. Scott *Invoice to David Nicolson dated 12 May 1897* Archives New Zealand/Te Rua Mahara o te Kawanatanga, Wellington Office Ref: DAAD D442 22e 164.
108. *New Zealand Gazette* (29 April 1897), p. 952.
109. *Otago Daily Times* (4 May 1897 p. 4, 5 May 1897 p. 3, 7 May 1897 p. 4, 8 May 1897 p. 6, 11 May 1897 p. 8, 12 May 1897 p. 4, 18 May 1897 p. 4, 20 May 1897 p. 3, 24 May 1897 p. 2).
110. *Otago Daily Times* (24 May 1897), p.2.
111. *D. Nicolson Bankruptcy valuation* (no named author, stamped "received 28 Apr 1897"). Archives New Zealand/Te Rua Mahara o te Kawanatanga, Wellington Office Ref: DAAD D442 22e 164.
112. *Stone's Otago Directory 1898*.
113. *New Zealand Gazette* (1 Sep 1898).
114. *Stone's Otago Directory 1899 & Stone's Otago Directory 1900*.
115. Electoral Rolls for *Dunedin City 1896 & 1897, Caversham 1896 & 1897*.
116. Cook and Gray *Letter from Cook & Gray, Accountants, Dunedin to Official Assignee, Dunedin dated Oct 12th 1897*. Archives New Zealand/Te Rua Mahara o te Kawanatanga, Wellington Office, Dunedin. Reference: DAAD D442 22f 164 (1897).
117. *New Zealand Gazette* (24 Mar 1898), p. 523.
118. *Stone's Otago Directory 1906*.
119. *Stone's Otago Directory 1908, Stone's Otago Directory 1909 & Stone's Otago Directory 1910*.
120. *Wises Directory 1908*.
121. Frederick Beadle *Probate* Archives New Zealand/Te Rua Mahara o te Kawanatanga, Wellington Office Ref: DAAC 9075 D239 4607.
122. Auto Machine Manufacturing Company Ltd *Directors Minute book (hand written)* Auckland : Fletcher Challenge Archives, Reference 1474/5/3 (1909).
123. National Machinery Co. *Letter to Auto Machine Mfg. Co. dated 9 Oct 1909*. Auckland : Fletcher Challenge Archives. Reference 1474-5-3a.
124. Consolidated Metal Industries Limited (CMI) *1909 – 1959 Our First Fifty Years* Auckland : CMI
125. See *Auto Machine Manufacturing Co Ltd Amalgamation P.H. Venables Ltd Christchurch December 1939 to December 1941*. Fletcher Challenge Archives. Reference 1474/2/3 – 35323.
126. Salmond *Old NZ Houses 1800-1940* pp. 58-9.
127. See, for example: Loveday, A.J. *The rise and decline of the American cut nail industry : a study of the interrelationships of technology, business organization, and management techniques* Westport, Conn. : Greenwood Press. (1983 ).

# CONSTRUCTION HISTORY

## Journal of the Construction History Society

### EDITORS

Robert Thorne, *Institute of Historical Research*  
Christopher Powell, *Cardiff University*  
Professor Simon Pepper (Abstracts Editor), *University of Liverpool*

### ADVISORY EDITORIAL BOARD

Nicholas Adams, *Vassar College*  
Michael Ball, *University of London*  
Donatella Calabi, *University Institute of Architecture, Venice*  
Jacques Heyman, *University of Cambridge*  
Werner Lorenz, *Brandenburg University of Technology, Cottbus*  
Antoine Picon, *Harvard University*  
Richard Rodger, *University of Edinburgh*  
Marcel Smets, *Catholic University of Leuven*

Construction History is an international journal devoted to the study of all aspects of the history of the building and construction, and to the development of construction history as a scholarly discipline. Founded in 1985 it is the only English-language periodical on the subject. The journal is published by Construction History Society, in association with the Chartered Institute of Building.

**Editorial correspondence**, including manuscripts for submission, should be addressed to Christopher Powell, Welsh School of Architecture, Cardiff University, Bute Building, King Edward VII Avenue, Cardiff CF10 3NB, United Kingdom. e-mail: powelleg@cardiff.ac.uk Articles should not normally exceed 6000 words in length, including references, although they may be much shorter. Intending contributors must first obtain from the Editor a copy of the 'Notes for Contributors', which lists the main literary conventions to be followed.

**Books for review**, and book reviews, should be sent to Robert Thorne, Institute of Historical Research, Senate House, London, WC1E 7HU, Great Britain.

**Material for abstracting** should be sent to Professor Simon Pepper, School of Architecture and Building Engineering, University of Liverpool, P.O. Box 147, Liverpool L69 3BX, United Kingdom.

**Business correspondence**, including orders and remittances to subscriptions, back numbers, offprints and advertisements, should be addressed to The Secretary, Construction History Society, c/o Library and Information Services Manager, The Chartered Institute of Building, Englemere, Kings Ride, Ascot, Berkshire SL5 7TB, United Kingdom.

This journal is published annually. This annual issue constitutes one volume. ISSN 0267-7768  
© 2009 The Construction History Society.

# CONSTRUCTION HISTORY

## Journal of the Construction History Society

Vol. 24 (2009)

Foreword	1
<b>Terracotta Vaulting Tubes in Roman Architecture: A Case Study of the Interrelationship Between Technologies and Trade in the Mediterranean</b> Lynne C. Lancaster	3
<b>Brunelleschi's dome revisited</b> Rowland Mainstone	19
<b>The Origins of Tile Vaulting in Valencia</b> Mercedes Gómez-Ferrer	31
<b>Cast Iron Windows in Anglican Churches in England 1791-1840</b> Ray Osborne	45
<b>The Operation of the Early Nineteenth-century Property Market</b> James Anderson	63
<b>Nails in New Zealand 1770 to 1910</b> Nigel Isaacs	83
<b>Modern Wood. De Coene at Expo 58</b> Rika Devos and Fredie Floré	103
<b>Abstracts of Periodical Literature</b> Compiled by Peter Richmond and Simon Pepper	121
<b>Book Reviews</b>	133
R W Brunskill, <i>Brick and Clay Building in Britain (Lawrance Hurst)</i> Adam Mornement and Simon Holloway, <i>Corrugated Iron. Building on the Frontier (Robert Thorne)</i> John G. Cox, <i>Samuel Morton Peto (1809-1889): the achievements and failings of a great railway developer</i> Adrian Vaughan, <i>Samuel Morton Peto: A Victorian Entrepreneur (Christopher Powell)</i> Mark Swenarton, <i>Building the New Jerusalem. Architecture, Housing and Politics 1900-1930 (Tanis Hinchcliffe)</i> Barry Bergdoll and Peter Christensen, <i>Home Delivery. Fabricating the Modern Dwelling (Andrew Rabeneck)</i> Maria E. Moreyra Garlock and David P. Billington, <i>Félix Candela. Engineer, Builder, Structural Artist. (Bill Addis)</i>	